

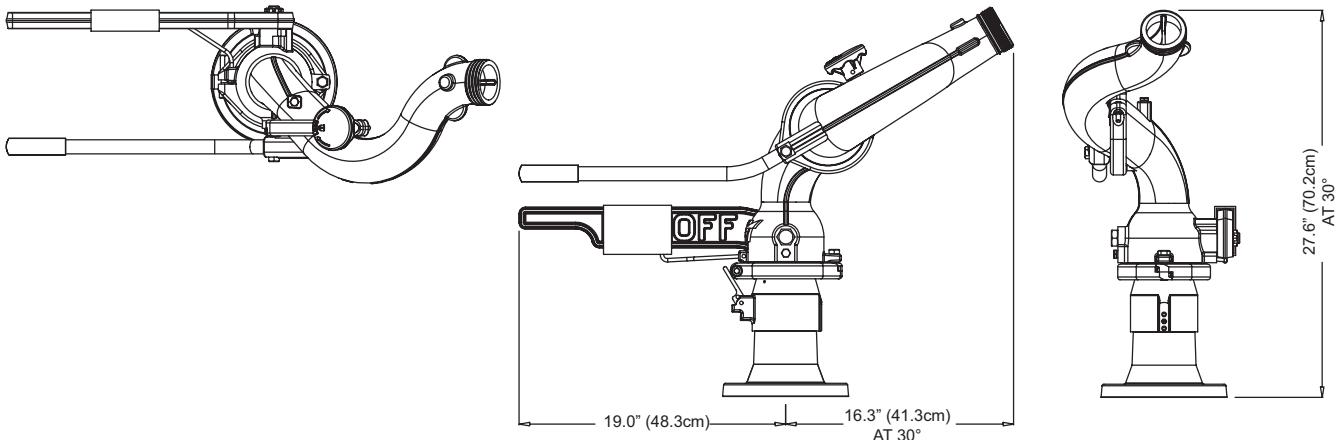

Fixed Station Monitor - Up To 1250 GPM

The Task Force Tips' Protector is a simple and rugged fixed station monitor with many unique features. Its patented waterway gives low friction loss and delivers water to the nozzle with fewer twists and turns than a conventional monitor. The optional built-in on/off valve with position indicator eliminates the need to add a costly valve to the monitor installation. The Protector is capable of flowing up to 1250 gpm (4500 l/min) while maintaining a FULL 360° rotational ability. The lever-action rotational lock is activated in one motion, visually confirmed, and securely holds the monitor's horizontal position. The Protector can be directly bolted to many common pipe flanges. The outlet is available with various 2.5" (65mm) male threads. The simple and basic design requires no grease application or other maintenance. Swiveling elements and seals (including valve seat) can be replaced within a few minutes with common hand tools. Threaded ports (0.25" NPT) (6mm) are provided for drain valve and pressure gauge installation. Maximum pressure is 250 psi (17 bar). The Protector is hardcoat anodized ANSI 356-T6 aluminum and is fully powder coat finished inside and out. Swivel clamps, 3" (75mm) valve ball, trunnions, and hardware are 18-8 stainless steel.



INLET SPECIFICATIONS

FITS FLANGE	OUTSIDE DIAMETER	THICKNESS	BOLT HOLE CIRCLE	NUMBER OF BOLTS	SIZE OF BOLTS
3" ANSI 125/150 - DN80 PN20	7.50" / 190 mm	0.75" / 20 mm	6.00" / 152.5 mm	4	5/8" / M16
4" ANSI 150 - DN100 PN20	9.00" / 230 mm	0.94" / 3 mm	7.50" / 90.5 mm	8	5/8" / M16
DN80 PN16	200 mm	22 mm	160 mm	8	16 mm
DN100 PN16	220 mm	22 mm	180 mm	8	16 mm

Valve with Threaded Exit - Protector monitor with on/off valve and 2.5" (65mm) threaded exit. 1250 gpm (4500 l/min) rating. See chart to obtain model number for specific inlet and outlet options.

Z1111A

35.2 lb (15.7kg)

SAMPLE PART NUMBER
Specify Inlet and Outlet by number from chart

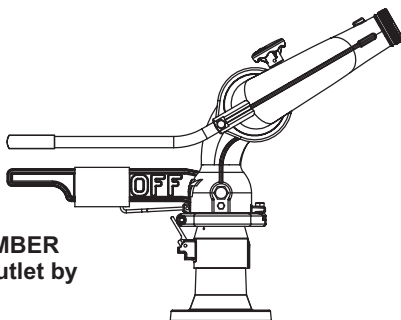

Z11

Inlet	Outlet
1) 3" ANSI 150	1) 2.5" (65mm) - 7.5 NH
2) 4" ANSI 150	2) 2.5" (65mm) - 11 BSP
4) DN80, PN16	3) 2.5" (65mm) - 11.5 NPSH
5) DN100, PN16	9) SPECIAL THREADS

A

No Valve with Threaded Exit - Protector monitor without on/off valve and with 2.5" (65mm) threaded exit. 1250 gpm (4500 l/min) rating. See chart to obtain model number for specific inlet and outlet options.

Z1211A

27.8 lb (12.6kg)

SAMPLE PART NUMBER
Specify Inlet and Outlet by number from chart

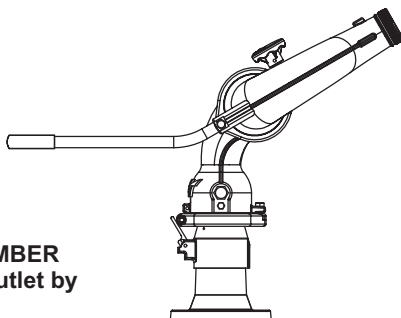

Z12

Inlet	Outlet
1) 3" ANSI 150	1) 2.5" (65mm) - 7.5 NH
2) 4" ANSI 150	2) 2.5" (65mm) - 11 BSP
4) DN80, PN16	3) 2.5" (65mm) - 11.5 NPSH
5) DN100, PN16	9) SPECIAL THREADS

A